

Actuators IC 20, IC 30, IC 50

Technical Information · GB
3 Edition 02.16l

- Easy to switch between Automatic and Manual mode
- Position indicator that can be read externally
- Three-point step control
- IC 20..E and IC 50..E also for continuous control
- IC 20..E, IC 50..E with electronic positioning function
- IC 50 for high torques and with selectable direction of rotation
- IC 30 for 24 V DC
- IC 20 and IC 50 can be delivered ready installed on control element
- IC 20, IC 50: adjustable motor behaviour in the event of cable discontinuity, for example



Contents

Actuators IC 20, IC 30, IC 50	1	3.5.2 Load impedance of the current input	20
Contents	2	3.5.3 Two-point step control	20
1 Application	4	3.5.4 Behaviour in the event of cable discontinuity (4 – 20 mA)	20
1.1 IC 20	6	3.6 IC 50..E DIP switches	21
1.2 IC 30	6	3.6.1 Choosing the input signal	21
1.3 IC 50	7	3.6.2 Load impedance of the current input	21
1.4 Examples of application	8	3.6.3 Two-point step control	21
1.4.1 Modulating control via three-point step signal	8	3.6.4 Behaviour in the event of cable discontinuity (4 – 20 mA)	21
1.4.2 Staged control via two-point step signal	9	3.6.5 Direction of rotation	21
1.4.3 Modulating control with continuous input signal	9	4 Replacement possibilities for actuators	22
1.4.4 IC 20, modulating control with burner control unit BCU	10	4.1 GT 31 is to be replaced by IC 20	22
1.4.5 IC 20..E, continuous control with burner control unit BCU	11	4.2 GT 31 is to be replaced by IC 30	23
1.4.6 IC 50, three-point step control with burner control unit BCU	12	4.3 GT 50 is to be replaced by IC 50	24
1.4.7 IC 50..E, continuous control with burner control unit BCU	13	5 Selection	25
2 Certification	14	5.1 Selection table	25
3 Function	15	5.2 IC 20 type code	25
3.1 Automatic/Manual mode	15	5.3 IC 30 type code	25
3.2 IC 20..T, IC 50..T connection diagram	16	5.4 IC 50 type code	25
3.2.1 Three-point step control	16	5.5 Butterfly valve torque, actuator running time	26
3.3 IC 20..E, IC 50..E connection diagram	17	5.5.1 IC 20 with BVG, BVA	26
3.3.1 Continuous control	17	5.5.2 IC 20 with BVGF, BVAF	26
3.3.2 Three-point step control	17	5.5.3 IC 20 with BVH	27
3.3.3 Two-point step control	17	5.5.4 IC 50 with DKR	27
3.4 IC 30 connection diagram	18	6 Project planning information	28
3.4.1 Three-point step control	18	6.1 Installation	28
3.4.2 In Manual mode	19	6.2 Cable selection	28
3.4.3 Low-fire/High-fire rate adjustment (in Manual mode only)	19	6.3 Electrical connection	28
3.4.4 Warnings and faults	19	6.4 IC 50, IC 50..E: changing the direction of rotation	29
3.5 IC 20..E DIP switches	20	6.5 Position feedback	29
3.5.1 Choosing the input signal	20	6.5.1 IC 20, IC 30, IC 50	29
		6.5.2 IC 20..E, IC 50..E	29

6.6 IC 20..E, IC 50..E, continuous control: adapting the input signal to the adjustment angle	30
7 Accessories	31
7.1 IC 20	31
7.1.1 Heat deflector	31
7.1.2 Adapter set for mounting onto a butterfly valve DKL, DKG	31
7.1.3 "Single application" attachment set	31
7.1.4 Potentiometer installation set	31
7.2 IC 30	32
7.2.1 Adapter set IC 30/VFC	32
7.3 IC 50	32
7.3.1 Wall mounting bracket	32
7.3.2 Heat deflector	32
7.3.3 Attachment sets	33
8 Technical data	34
8.1 IC 20, IC 50	34
8.1.1 IC 20, IC 20..E	34
8.1.2 IC 50, IC 50..E	35
8.2 IC 30	36
8.3 Dimensions	37
8.3.1 IC 20	37
8.3.2 IC 30	37
8.3.3 IC 50	38
9 Converting units	39
10 Maintenance	39
Feedback	40
Contact	40



IC 20

IC 30

IC 50

1 Application

The actuators are designed for all applications that require precise, controlled rotary movement between 0° and 90°. In conjunction with a control element, they are suitable for regulating flow rates on gas and air appliances for modulating or stage-controlled combustion processes.

In addition to setting the Min. and Max. positions using infinitely adjustable switching cams, floating limit switches mean that additional switching positions such as for ignition and high-fire rate positions can be set.

A standard Service switch allows the device to be switched from Automatic to Manual mode and a position indicator which can be read from the outside drastically simplifies the commissioning procedure.

IC 20, IC 30 and IC 50 are controlled by a three-point step signal. IC 20..E and IC 50..E can also be controlled by a continuous signal.

An integrated feedback potentiometer offers the option of monitoring the current position of the actuator. This checking function can be used in automation processes.

IC 20..E, IC 50..E

The behaviour of the actuator, e.g. if the input signal falls below the minimum limit in the event of cable discontinuity, can be set using DIP switches.

Fluctuations or interference in the input signal are suppressed by an adjustable potentiometer. In the case of continuous control, the input signal can be adapted to the minimum and maximum adjustment angles manually or automatically. This calibration process can be

Application

visualized using LEDs. The continuous signal offers the option of monitoring the current position of the actuator.



Roller hearth kiln in the ceramics industry



Forging furnace



CHP for generating electricity and heat

1.1 IC 20

The actuator IC 20 can be mounted directly onto the butterfly valves BVG, BVGF, BVA, BVAF, BVH or BVHS. The combination is designed for control ratios up to 10:1.

See www.docuthek.com, Butterfly valves BVG, BVA, BVH, Technical Information.

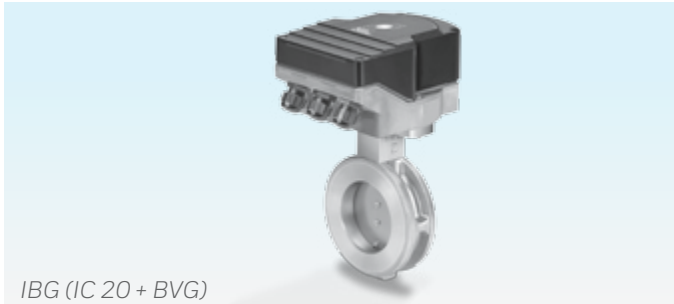

IBG (IC 20 + BVG)

Actuator IC 20 and linear flow control VFC can be delivered ready assembled. The combination is designed for control ratios up to 25:1.

See www.docuthek.com, Linear flow controls VFC, Technical Information.

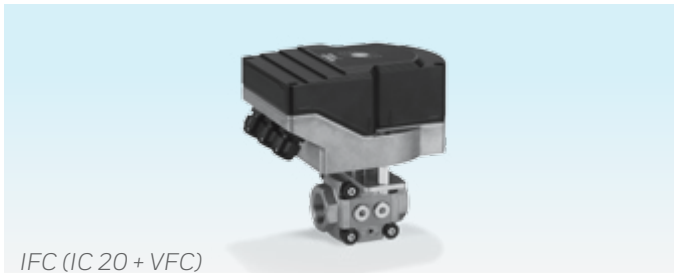

IFC (IC 20 + VFC)

1.2 IC 30

Actuator IC 30 is used as an actuator for linear flow control VFC. An adapter set must be used for assembly. The IC 30, linear flow control VFC and the adapter set are not assembled on delivery.

This combination is designed for a control ratio of up to 25:1.

IC 30 is suitable for 24 V DC applications.

See www.docuthek.com, Linear flow controls VFC, Technical Information.

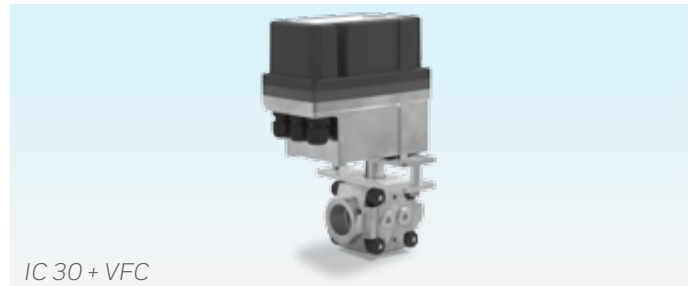

IC 30 + VFC

1.3 IC 50

IC 50 is designed for applications with high torques of up to 30 Nm.

Actuator IC 50 and butterfly valve DKR are also delivered ready assembled up to nominal size 300.

The direction of rotation of the valve disc can be switched. The valve disc position can be read from the outside whereby the direction of rotation is indicated using a colour code.

Depending on the application, the actuator can be aligned to the butterfly valve using various attachment sets. See www.docuthek.com, Butterfly valves DKR, Technical Information.

Axial mounting

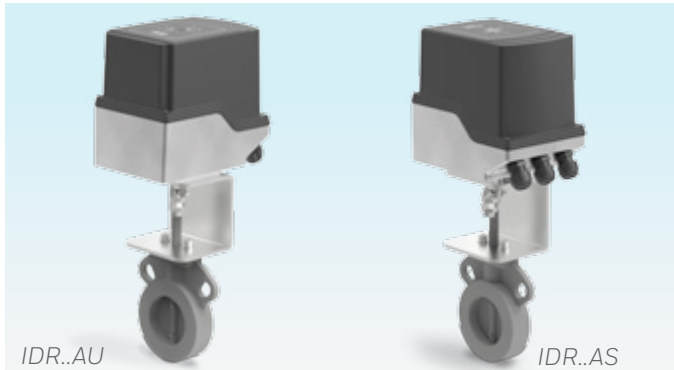

The actuator is axially aligned to butterfly valve DKR and can be mounted rotated in increments of 90°.

connections are then positioned above the pipe or to the side of the pipe.

Attachment with linkage

If the actuator is to be operated offset to the side of the butterfly valve, an attachment set with linkage can be used. The actuator may be installed rotated by 180°.



This attachment set ..GD is used for butterfly valves with disc clearance DKR..D.



In the case of butterfly valves with stop bar DKR..A, an attachment set. GA with shock suppressor must be used.

As of a medium temperature of $> 250^{\circ}\text{C}$, the actuator is to be protected by a heat deflector, see page 32 (Heat deflector).

1.4 Examples of application

1.4.1 Modulating control via three-point step signal

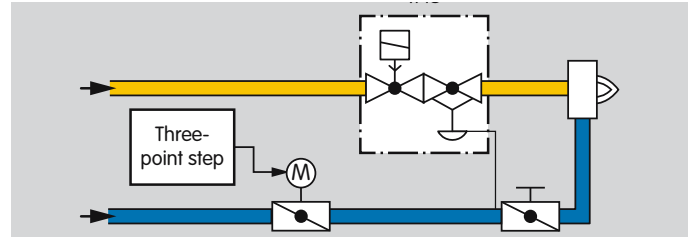

For processes that require high temperature accuracy and low circulation in the furnace. Actuator IC is controlled by a three-point step controller and moves the butterfly valve to the ignition position. The burner starts. The butterfly valve opens or closes between the low-fire/high-fire rate positions depending on the capacity demand of the burner. When the three-point step signal is disconnected, the butterfly valve stops at its current position.

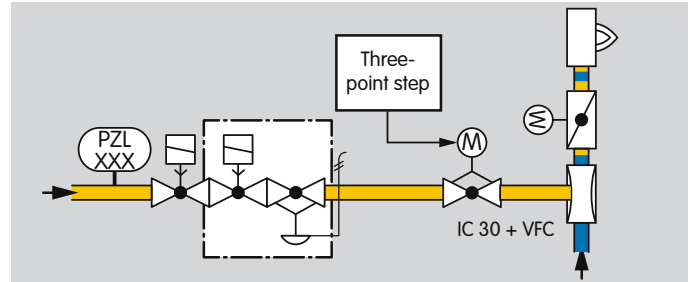

For processes that require high control accuracy. The low-fire and high-fire rates are adjusted using the con-

Application

trol element upstream of the burner. Actuator IC 30 is controlled by a three-point step controller and ensures the desired gas/air mixture is produced.

1.4.2 Staged control via two-point step signal

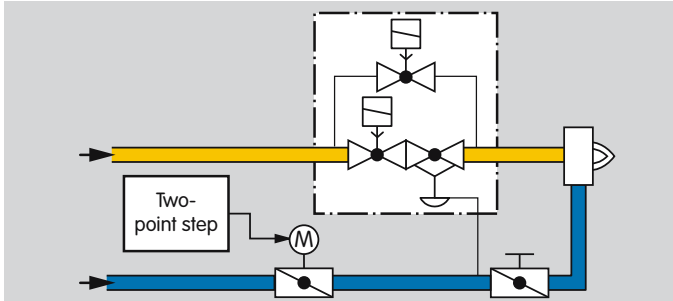

For processes that require a homogeneous temperature distribution in the furnace. Actuator IC..E is controlled by a two-point step controller and operates in On/Off or High/Low intermittent mode. The actuator closes when the voltage supply is disconnected.

1.4.3 Modulating control with continuous input signal

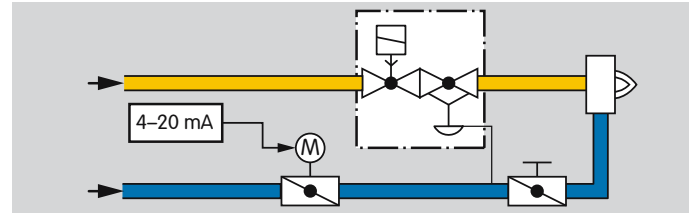

For processes that require high temperature accuracy and low circulation in the furnace. Actuator IC..E is controlled by a (0) 4 – 20 mA or 0 – 10 V signal. The continuous signal corresponds to the adjustment angle to be approached and offers the option of monitoring the current position of the actuator.

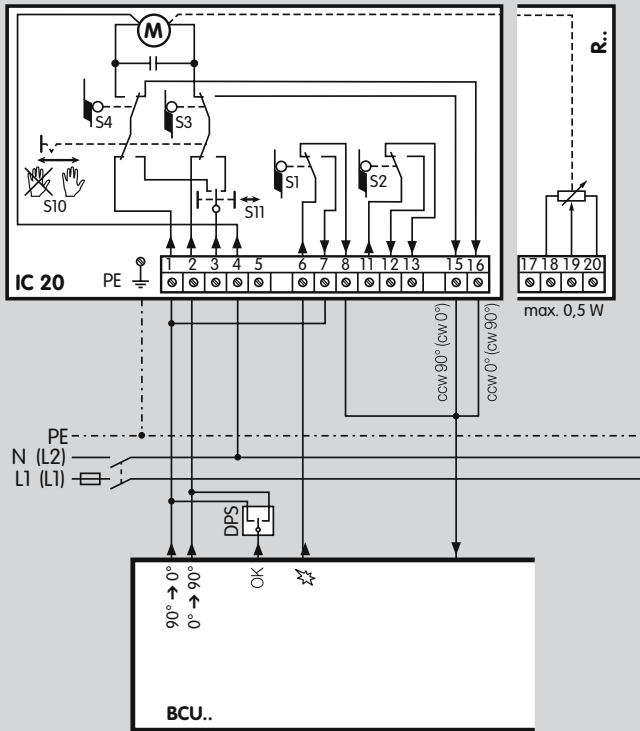

1.4.4 IC 20, modulating control with burner control unit BCU

The BCU moves the butterfly valve to pre-purge and ignition positions. After pre-purge and burner start, the controller enable signal is issued to an external three-point step controller which positions the butterfly valve in accordance with the capacity demand.

Once the pre-purge or ignition positions has been reached, a feedback signal is sent to the BCU.

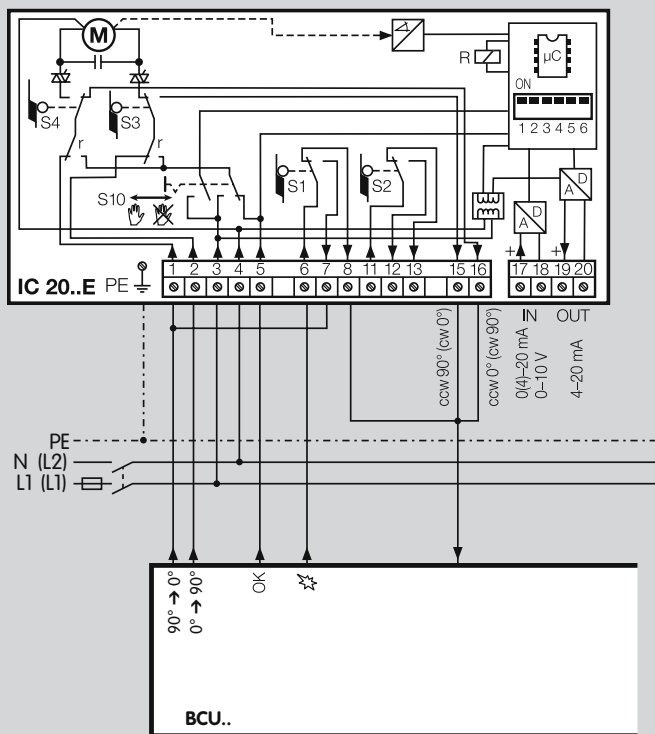

1.4.5 IC 20..E, continuous control with burner control unit BCU

The BCU controls pre-purge and moves the butterfly valve to pre-purge and ignition positions.

Once the BCU has started the burner, the modulation enable signal is issued via terminal 5 (OK). Actuator IC 20..E reacts to the (0) 4 – 20 mA or 0 – 10 V setpoint specification signals.

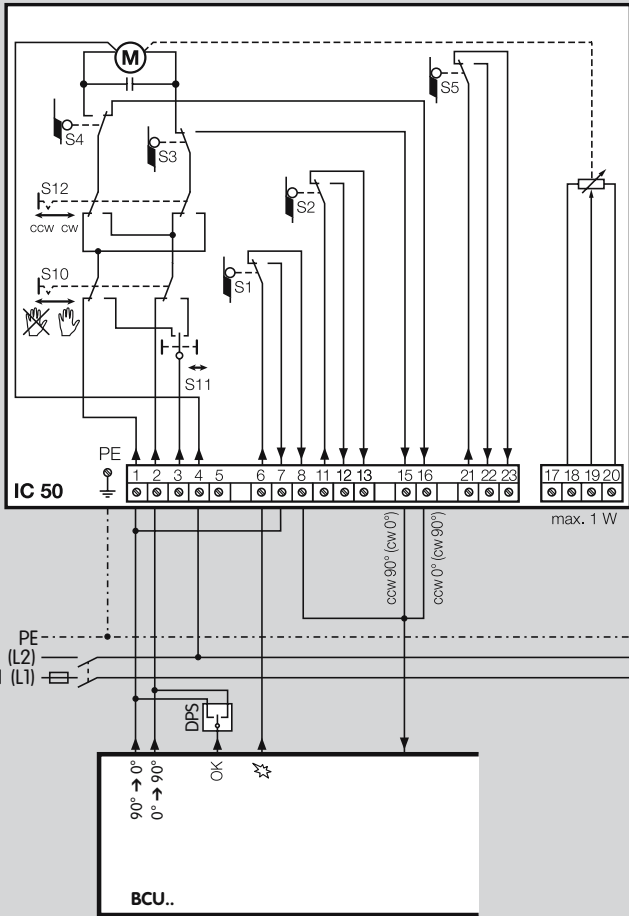

1.4.6 IC 50, three-point step control with burner control unit BCU

The BCU moves the butterfly valve to pre-purge and ignition positions. After pre-purge and burner start, the controller enable signal is issued to an external three-point step controller which positions the butterfly valve in accordance with the capacity demand.

Once the pre-purge or ignition position has been reached, a feedback signal is sent to the BCU.

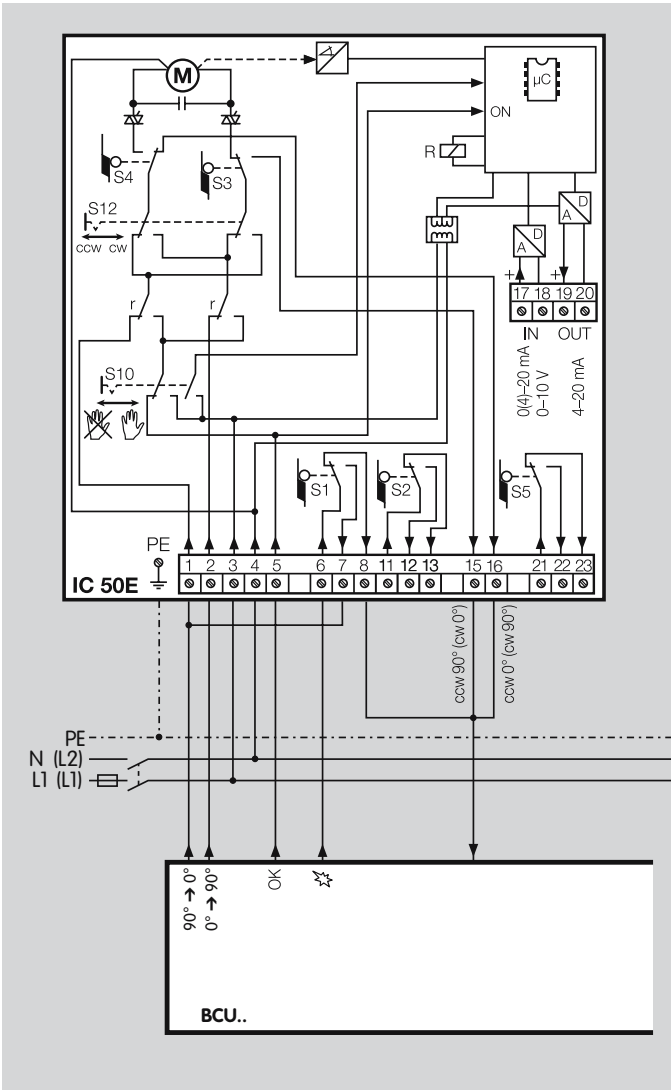

1.4.7 IC 50..E, continuous control with burner control unit BCU

The BCU controls pre-purge and moves the butterfly valve to pre-purge and ignition positions.

Once the BCU has started the burner, the modulation enable signal is issued via terminal 5 (OK). Actuator IC 50..E reacts to the (0) 4 – 20 mA or 0 – 10 V setpoint specification signals.

2 Certification

Certificates – see Docuthek.

EU certified

IC 20, IC 50



Meets the requirements of the

- Low Voltage Directive (2006/95/EC),
- EMC Directive (2004/108/EC) on the basis of EN 60730.

Eurasian Customs Union



The product IC 20/IC 50 meets the technical specifications of the Eurasian Customs Union (the Russian Federation, Belarus, Kazakhstan).

3 Function

The actuator moves towards 0° or 90° if it is energized electrically at the related terminal. If the voltage is disconnected, the actuator stops at the current position. A high holding torque when de-energized renders additional braking elements superfluous. The low-fire and high-fire rates are adjusted using infinitely adjustable switching cams. An integrated feedback potentiometer (optional on IC 20, IC 30) makes it possible to monitor the current position of the actuator.

IC..E

In normal operation, input "OK" is supplied with voltage. The setpoint device issues an actuating signal (0 (4) – 20 mA, 0 – 10 V). The continuous signal corresponds to the adjustment angle to be approached (e.g. with a 0 to 20 mA signal, 10 mA correspond to a valve angle of 45°).

3.1 Automatic/Manual mode

Switchover between Automatic and Manual mode facilitates setting of the infinitely adjustable switching cams during commissioning. This enables precise settings even in the low-fire rate range.

The switching point is set directly on the cams.

External devices can be activated or intermediate positions can be checked via additional, floating, infinitely adjustable switches. The IC 30 has one adjustable switching cam, the IC 20 has two and the IC 50 has three.

3.2 IC 20..T, IC 50..T connection diagram

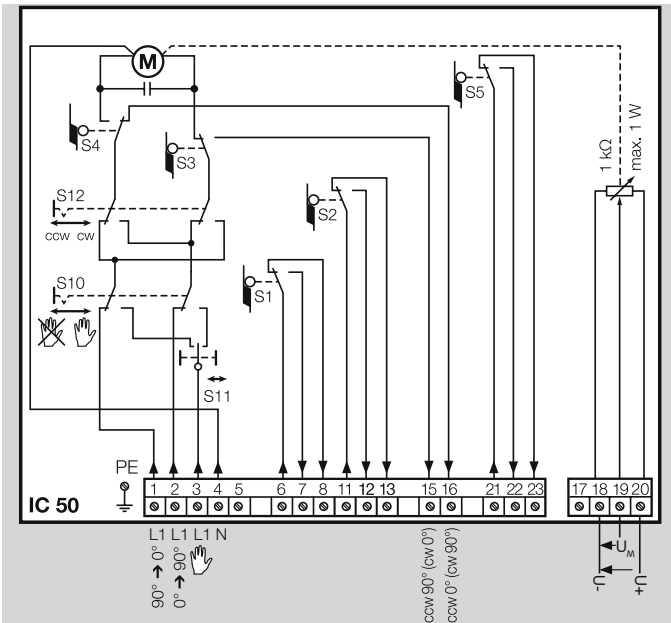
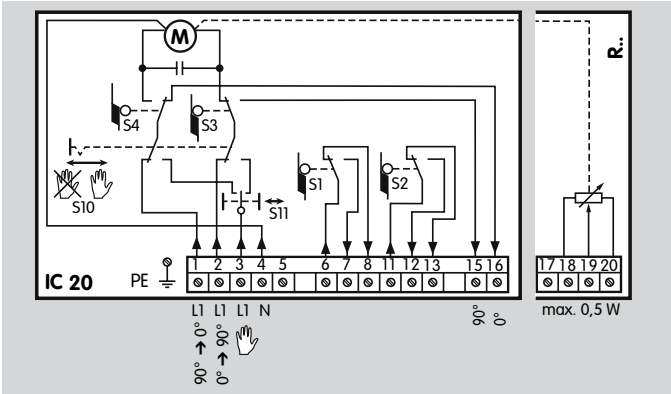

3.2.1 Three-point step control

In the case of default setting “Closed”: The control element opens when voltage is applied to terminal 2. The control element closes when voltage is applied to terminal 1. See page 28 (Project planning information).

3.3 IC 20..E, IC 50..E connection diagram

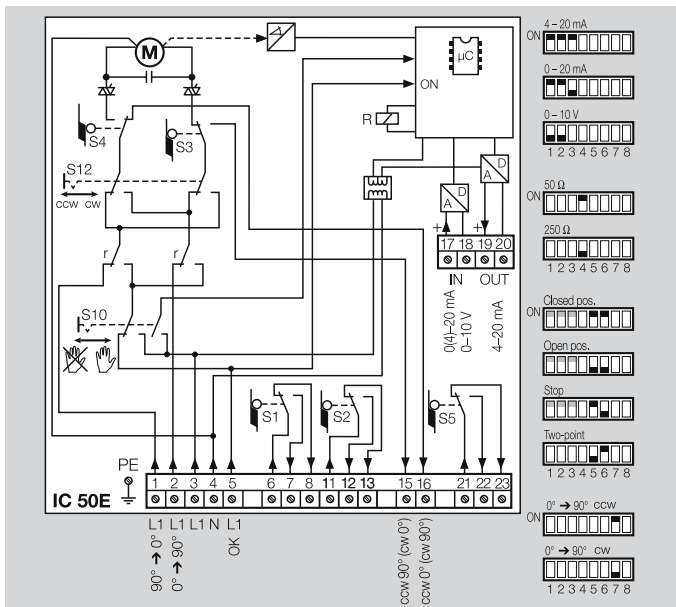
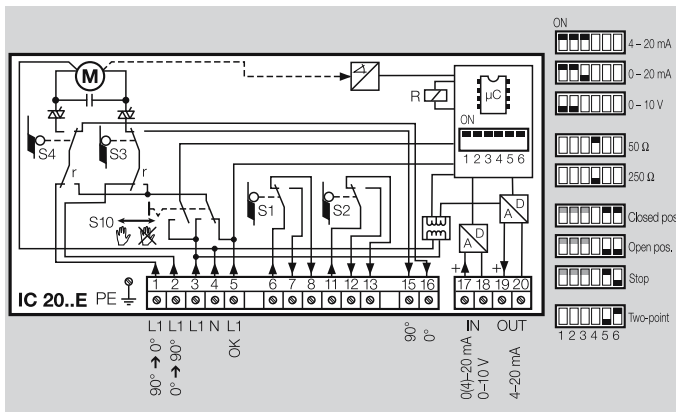

3.3.1 Continuous control

Voltage is applied to terminal 5. Following successful modulation enable via terminal 5 (OK), the actuator reacts to the setpoint specification (0 (4) – 20 mA, 0 – 10 V) via terminals 17 and 18. The pre-purge and ignition positions are controlled via terminals 1 and 2.

The IC..E offers the option of monitoring the current position of the actuator via terminals 19 and 20.

See page 28 (Project planning information).

3.3.2 Three-point step control

No voltage at terminal 5. Voltage must be applied to terminals 3 and 4 continuously.

Two-point step control must be deactivated at the DIP switch.

3.3.3 Two-point step control

Connect voltage to terminals 1 and 3. Set the DIP switches to 2-point step control. If an input signal is applied to terminal 5 (OK), the actuator opens. If no input signal is applied to terminal 5, the actuator closes.

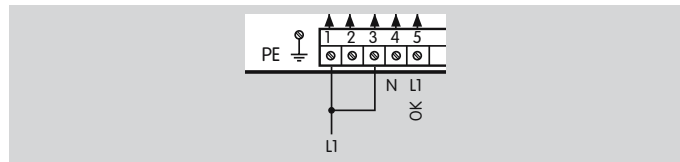

3.4 IC 30 connection diagram

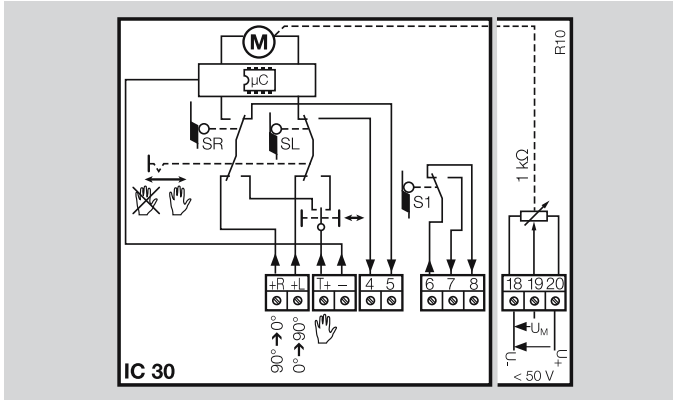

3.4.1 Three-point step control

In the case of default setting “Closed”: The control element opens when voltage is applied to terminal +L. The control element closes when voltage is applied to terminal +R. To activate Manual mode, voltage must be applied to terminal T+. IC 20..E display.

3.4.2 In Manual mode

Blue LED	Red LED	Operating state
Lit	Off	Manual mode
Flashing	Flashing	Calibration (in Manual mode only)

3.4.3 Low-fire/High-fire rate adjustment (in Manual mode only)

Blue LED	Red LED	Operating state
Lit	On for 0.5 s	Min. value \geq max. value*
Off for 0.5 s	Off	Min. or Max. setting accepted

* Value will only be accepted, if the min or max button is pressed for another three seconds

3.4.4 Warnings and faults

Blue LED	Red LED	Warning/ fault	Description	Cause
Off	Flashing light (1x)	Warning	The device is in 4 – 20 mA mode, the input signal is < 3 mA	Cable discontinuity on the 4 – 20 mA setpoint input
Off	Flashing light (2x)	Warning	Many changes of direction, input signal oscillates	Hysteresis set too small
Off	Flashing light (3x)	Warning	Control range < 1°	Device programming error (Min. and Max. positions)
Flashing light (1x)	Permanent light	Fault	Calibration not successful	Min. or Max. position has not been reached, motor defective, gear defective, potentiometer defective
Flashing light (2x)	Permanent light	Fault	Internal error	Unit defective

3.5 IC 20..E DIP switches

The input signals for the actuator can be set via DIP switches. DIP switch positions that are not indicated can be freely selected.

■ = switch position

3.5.1 Choosing the input signal

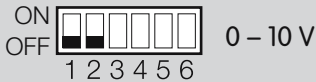

3.5.2 Load impedance of the current input



3.5.3 Two-point step control

Burner control: On/Off or High/Low

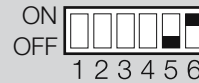

3.5.4 Behaviour in the event of cable discontinuity (4 – 20 mA)

Butterfly valve moves to CLOSED position



Butterfly valve moves to OPEN position



Butterfly valve stops

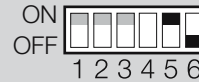

3.6 IC 50..E DIP switches

The input signals for the actuator can be set via DIP switches. DIP switch positions that are not indicated can be freely selected.

■ = switch position

3.6.1 Choosing the input signal

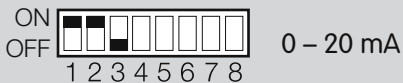

3.6.2 Load impedance of the current input



3.6.3 Two-point step control

Burner control: On/Off or High/Low

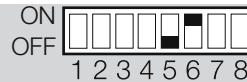

3.6.4 Behaviour in the event of cable discontinuity (4 – 20 mA)

Butterfly valve moves to CLOSED position



Butterfly valve moves to OPEN position



Butterfly valve stops



3.6.5 Direction of rotation

Butterfly valve opens clockwise CW



Butterfly valve opens anti-clockwise CCW



4 Replacement possibilities for actuators

4.1 GT 31 is to be replaced by IC 20

Type			Type
GT 31	Actuator	Actuator	IC 20
03	Running time [s/90°]: 3.7 s	Running time [s/90°]: 3.7 s	-
07	7.5 s	7.5 s	07
15	15 s	15 s	15
30	30 s	30 s	30
60	60 s	60 s	60
H	Mains voltage: 24 V AC, 50/60 Hz	Mains voltage: -	-
M	110/120 V AC, 50/60 Hz	120 V AC, 50/60 Hz	Q
T	220/240 V AC, 50/60 Hz	230 V AC, 50/60 Hz	W
1	Torque: 1.2 Nm	-	-
2	Torque: 2.5 Nm	Torque: 2.5 Nm	2
3	Torque: 3.0 Nm	Torque: 3.0 Nm	3
●	Three-point step control	Three-point step control	T
R	Two-point step control	Two-point step control	●
E	Continuous control	Continuous control	E
G	Additional switches with gold contacts	24 - 230 V position switch	●
○ ¹⁾	1000 Ω feedback potentiometer	1000 Ω feedback potentiometer	R10

Example

GT 31-30T3R

● = standard, ○ = available

¹⁾ See separate type label on the device

Example

IC 20-30W3

4.2 GT 31 is to be replaced by IC 30

Type			Type
GT 31	Actuator	Actuator	IC 30
03	Running time [s/90°]: 3.7 s	Running time [s/90°]:-	-
07	7.5 s	-	-
15	15 s	-	-
30	30 s	30 s	30
60	60 s	60 s	60
K	Mains voltage: 24 V DC, ± 20%	Mains voltage: 24 V _~ , ± 20 %	K
M	110/120 V AC, 50/60 Hz	-	-
T	220/240 V AC, 50/60 Hz	-	-
1	Torque: 1.2 Nm	-	-
2	Torque: 2.5 Nm	-	-
3	Torque: 3.0 Nm	Torque: 3.0 Nm	3
●	Three-point step control	Three-point step control	T
R	Two-point step control	-	-
E	Continuous control	-	-
G	Additional switches with gold contacts	-	-
○ ¹⁾	1000 Ω feedback potentiometer	1000 Ω feedback potentiometer	R10

Example

GT 31-30K3

● = standard, ○ = available

¹⁾ See separate type label on the device

Example

IC 30-30K3TR10

4.3 GT 50 is to be replaced by IC 50

Type			Type
GT 50	Actuator	Actuator	IC 50
03	Running time [s/90°]: 3.7 s	Running time [s/90°]: 3.7 s	03
07	7.5 s	7.5 s	07
15	15 s	15 s	15
30	30 s	30 s	30
60	60 s	60 s	60
H	Mains voltage: 24 V AC, 50/60 Hz	Mains voltage: 24 V AC, 50/60 Hz	H
M	110/120 V AC, 50/60 Hz	120 V AC, 50/60 Hz	Q
T	220/240 V AC, 50/60 Hz	230 V AC, 50/60 Hz	W
4	Torque: 3.7 Nm	Torque: 3 Nm	3
7	Torque: 7.5 Nm	Torque: 7 Nm	7
15	Torque: 15 Nm	Torque: 15 Nm	15
20	Torque: 20 Nm	Torque: 20 Nm	20
-	-	Torque: 30 Nm	30
-	-	Three-point step control	T
R	Two-point step control	Two-point step control	●
E	Continuous control	Continuous control	E
G	Additional switches with gold contacts	-	-
U	Reversed direction of rotation	1000 Ω feedback potentiometer	R10

Example

GT 50-15T20E

● = standard, ○ = available

Example

IC 20-15W20E

5 Selection

5.1 Selection table

	-03	-07	-15	-30	-60	K	W	Q	H	2	3	7	15	20	30	E	T	R10
IC 20	●	●	●	●		●	●			●	●					○	●	○ ¹⁾
IC 30			●	●		●				●							●	○ ¹⁾
IC 50	●	●	●	●	●	●	●	●	●	●	●	●	●	●	●	○	●	●

¹⁾ Optional on IC 20. If "none", this specification is omitted.

● = standard, ○ = available

Example

IC 50-15W30TR10

5.2 IC 20 type code

Code	Description
IC 20	Actuator
	Running time in s/90°:
-07	7.5
-15	15
-30	30
-60	60
	Mains voltage:
W	230 V AC, 50/60 Hz
Q	120 V AC, 50/60 Hz
	Torque:
2	2.5 Nm
3	3 Nm
	Continuous control
E	Three-point step control
T	
R10	Feedback potentiometer

5.3 IC 30 type code

Code	Description
IC 30	Actuator
	Running time in s/90°:
-30	30
-60	60
K	Mains voltage 24 V DC, ± 20%
3	Torque 3 Nm
T	Three-point step control
R10	Feedback potentiometer

5.4 IC 50 type code

Code	Description
IC 50	Actuator
	Running time in s/90°:
-03	3.7
-07	7.5
-15	15
-30	30
-60	60
	Mains voltage:
W	230 V AC, 50/60 Hz
Q	120 V AC, 50/60 Hz
H	24 V AC, 50/60 Hz
	Torque:
3	3 Nm
7	7.5 Nm
15	15 Nm
20	20 Nm
30	30 Nm
	Continuous control
E	Three-point step control
T	
R10	Feedback potentiometer

5.5 Butterfly valve torque, actuator running time

The characteristic curves relate to the maximum torque produced by the flow rate. In general, maximum torque is reached at approx. 70°.

The running time of the actuator per 90° depends on the required torque.

The running time is reduced by a factor of 0.83 at a frequency of 60 Hz on the actuator.

5.5.1 IC 20 with BVG, BVA

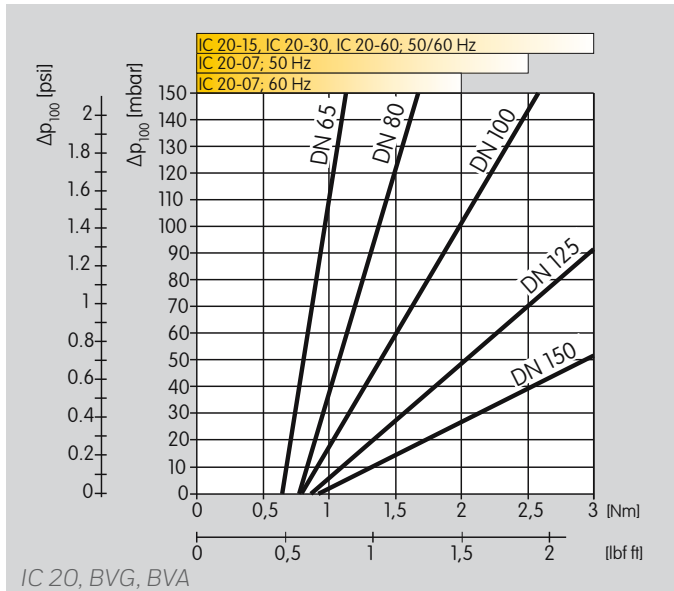

5.5.2 IC 20 with BVGF, BVAF

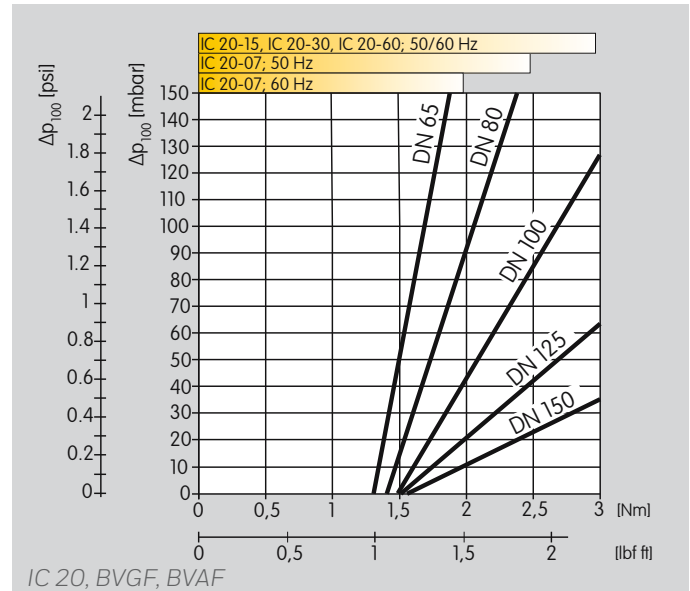

5.5.3 IC 20 with BVH

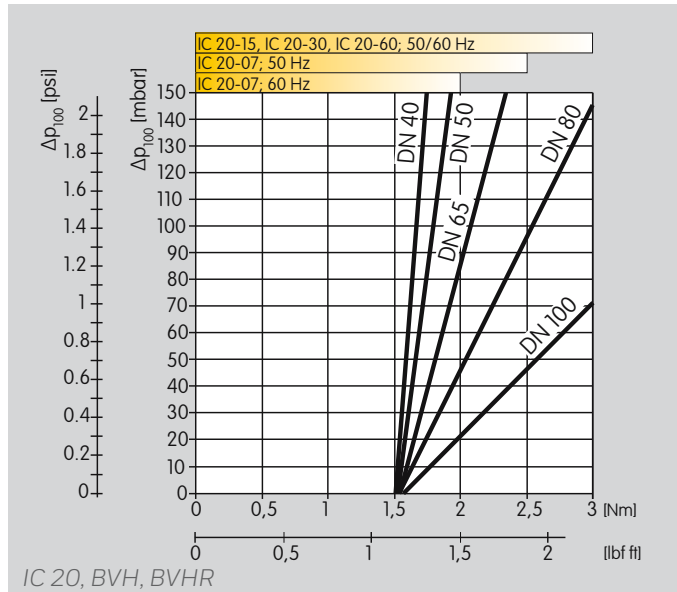

5.5.4 IC 50 with DKR

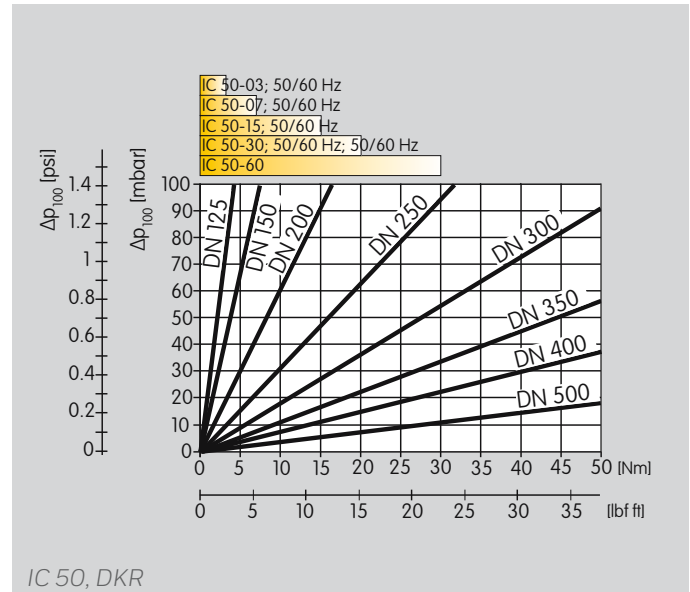

6 Project planning information

6.1 Installation

Installation position

IC 20, IC 50: vertical or horizontal, not upside down.

IC 30: any.

If the actuator is used with hot air, the pipeline should be adequately insulated so as to reduce the ambient temperature. In order to avoid overheating, the flanges and butterfly valve must not be insulated.

Use heat deflectors for a medium temperature of > 250°C, see IC 20, pages 31 (Heat deflector) and IC 50 pages, 32 (Heat deflector).

IC 20

In order to mount actuator IC 20 onto control elements other than DKL, DKG, BVA, BVAF, BVG, BVGF, BVH, BVHS or VFC, the attachment set for “single application” is required, see page 31 (“Single application” attachment set).

IC 30

In order to mount actuator IC 30 onto linear flow control VFC, an adapter set is required, see page 32 (Adapter set IC 30/VFC).

IC 50

Actuator IC 50 can be mounted directly onto a wall using a bracket, see page 32 (Wall mounting bracket).

Attachment sets are available for mounting to butterfly valve DKR, see page 33 (Attachment sets).

6.2 Cable selection

Install supply and signal lines separately.

Cables should be installed well away from high-voltage lines of other devices.

IC 30: feedback potentiometer lines should be equipped with additional shielding.

Observe EMC Directive for installation of signal lines.

Use cables with wire end ferrules.

Cable cross-section: max. 2.5 mm².

Conductors which have not been connected (spare conductors) must be insulated at their ends.

6.3 Electrical connection

IC 20, IC 50: running times are reduced by a factor of 0.83 at 60 Hz compared to 50 Hz.

When operating two or more actuators in parallel, the three-point step controller (terminals 1 and 2) must be electrically isolated to avoid leakage currents. We recommend using relays.

Interference suppression capacitors installed in the system must only be used in conjunction with a series resistor so as not to exceed the maximum current – see page 34 (Technical data).

IC 20..E, IC 50..E: three-point step control

When no voltage is applied to terminal 5, three-point step control is active. Two-point step control must be switched off at the DIP switch.

6.4 IC 50, IC 50..E: changing the direction of rotation

The function of switching cams S3/S4 changes if the direction of rotation ccw/cw (anti-clockwise/clockwise) is modified. The actuator is set to ccw at the factory.

ccw: S3 = maximum angle, S4 = minimum angle.

cw: S3 = minimum angle, S4 = maximum angle.

IC 50..E

When changing the direction of rotation, both DIP switch 7 and switch S12 must be in the same position (cw/ccw).

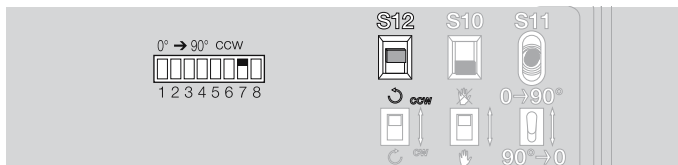

6.5 Position feedback

6.5.1 IC 20, IC 30, IC 50

A feedback potentiometer offers the option of monitoring the current position of the actuator.

In the case of actuator IC 30, IC 50, the feedback potentiometer is included in the delivery. In the case of

actuator IC 20, the feedback potentiometer can be retrofitted, see page 31 (Potentiometer installation set).

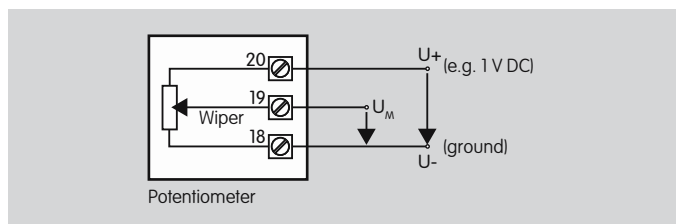

It must be utilized as a voltage divider. The change in position of the potentiometer wiper (which corresponds to the actuator position) can be measured as a changing voltage between U_M and U_- .

Other circuit layouts produce measurement results that are inaccurate and do not remain stable over a long period of time or are non-reproducible. They also reduce the service life of the feedback potentiometer.

IC 30: once the switching cams have been adjusted, the potentiometer automatically adjusts itself to the setting travel via the integrated slip clutch.

6.5.2 IC 20..E, IC 50..E

The IC..E offers the option of monitoring the current position of the actuator via the continuous 4 – 20 mA output signal (terminals 19 and 20).

Position feedback at terminals 15 and 16: interference suppression capacitors installed in the system must only be used in conjunction with a series resistor so as not to exceed the maximum switch-on, see page 34 (Technical data).

6.6 IC 20..E, IC 50..E, continuous control: adapting the input signal to the adjustment angle

The continuous signal corresponds to the adjustment angle to be approached (e.g. with a 0 to 20 mA signal, 10 mA correspond to a valve angle of 45°).

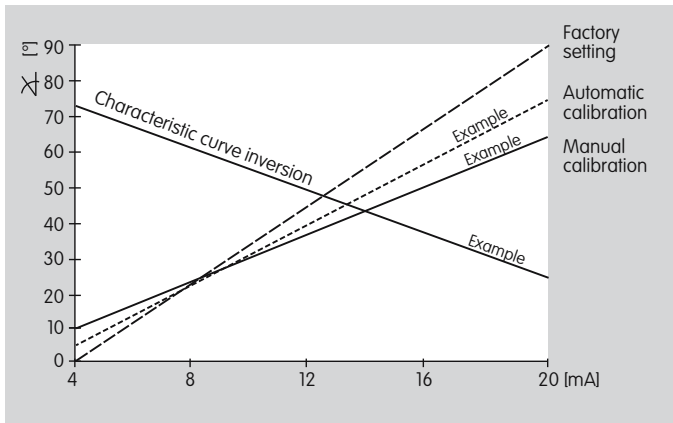

Automatic calibration

If the factory setting is changed, the mA signal for the minimum and maximum opening angles must be confirmed via automatic calibration. The setpoint specification will then correspond to the setting of switching cams S3 and S4.

Manual calibration

If the mA signal is to be used for modulation between the minimum and maximum opening angles, the signal is set via manual calibration.

Characteristic curve inversion

If the mA value for low fire has to be greater than the mA value for high fire: press the min or max button until the red LED lights up briefly (approx. 0.5 seconds) and hold it in for approx. 3 seconds more until the blue LED goes out briefly (approx. 0.5 seconds).

7 Accessories

7.1 IC 20

7.1.1 Heat deflector

Install heat deflectors in order to protect the actuator from overheating if the medium temperature is $> 250^{\circ}\text{C}$.

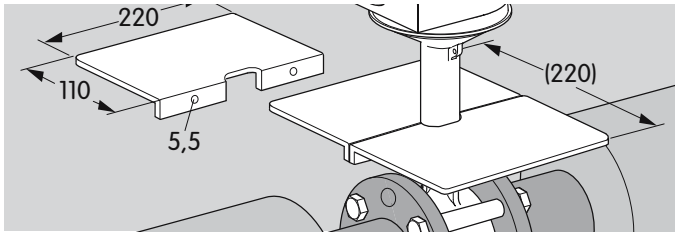

Order No.: 74921670

7.1.2 Adapter set for mounting onto a butterfly valve DKL, DKG

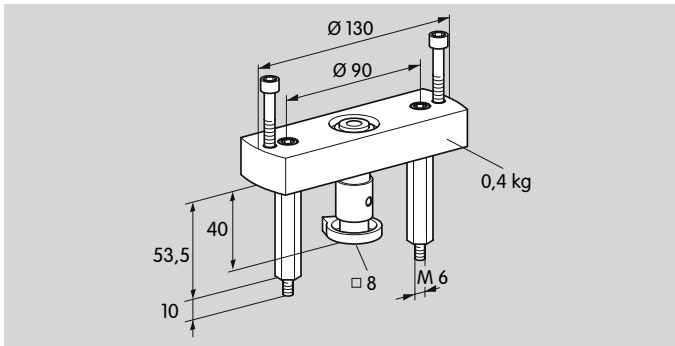

Order No.: 74921672

7.1.3 "Single application" attachment set

This attachment set is required if the actuator is mounted onto control elements other than DKL, DKG, BVA, BVAF, BVG, BVGF, BVH, BVHS or VFC.

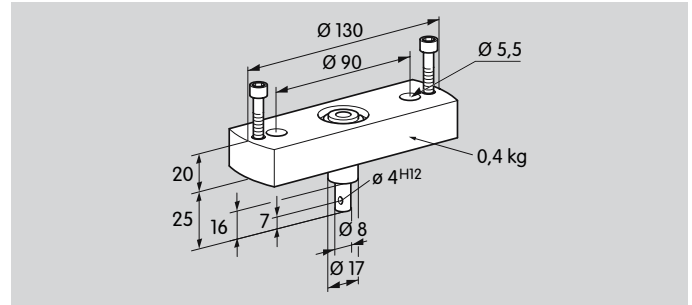

Order No.: 74921671

7.1.4 Potentiometer installation set

1000 Ω feedback potentiometer.

The power consumption of the potentiometer is max. 0.5 W.

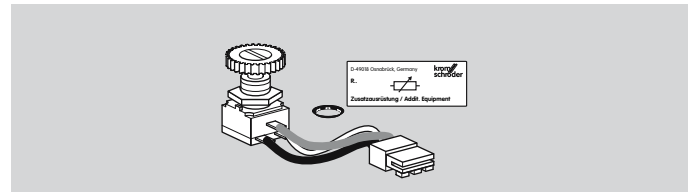

Order No.: 74921144

7.2 IC 30

7.2.1 Adapter set IC 30/VFC

For the assembly of IC 30 and VFC.

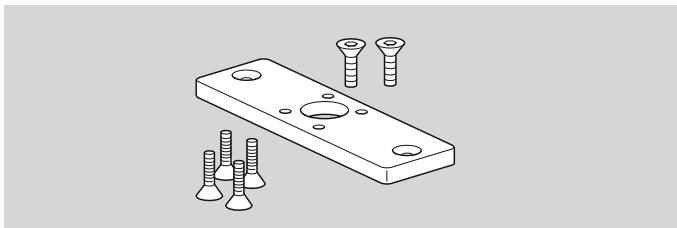

Order No.: 74340194

7.3 IC 50

7.3.1 Wall mounting bracket

The actuator can be attached to a solid structure using the wall mounting bracket.

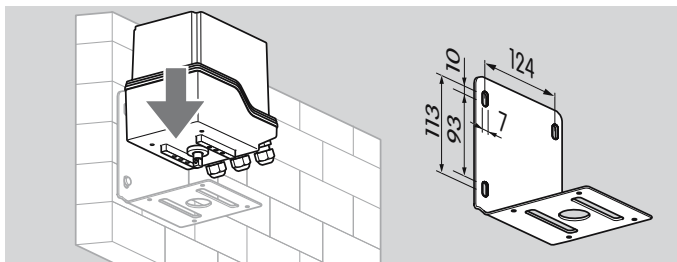

Order No.: 74924791

7.3.2 Heat deflector

Install heat deflectors in order to protect the actuator from overheating if the medium temperature is $> 250^{\circ}\text{C}$.

If used in conjunction with butterfly valves DKR, heat deflectors of various dimensions can be installed.

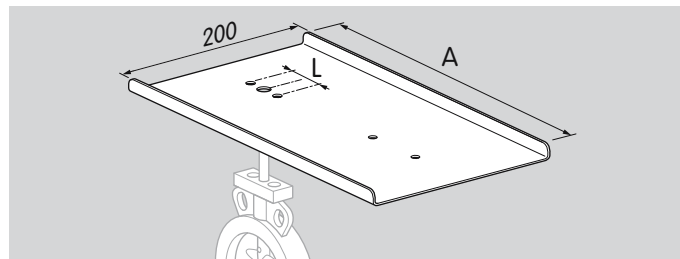

	L	A	Order No.
DKR 15 - 20	36	366	74924966
DKR 25 - 32	36	366	74924967
DKR 40 - 50	40	366	74924968
DKR 65 - 100	40	366	74924969
DKR 125	40	459	74924970
DKR 150 - 250	60	459	74924971
DKR 300	60	566	74924972
DKR 350	90	619	74924973
DKR 400 - 500	90	758	74924974

7.3.3 Attachment sets

Pre-assembled combinations of actuators, attachment sets and butterfly valves are available as models IDR up to nominal size DN 300.

The actuator, attachment set and butterfly valve can also be ordered separately.

Axial mounting

The actuator can be mounted to the U bracket in increments of 90°. The connections are then positioned above the pipe or to the side of the pipe.

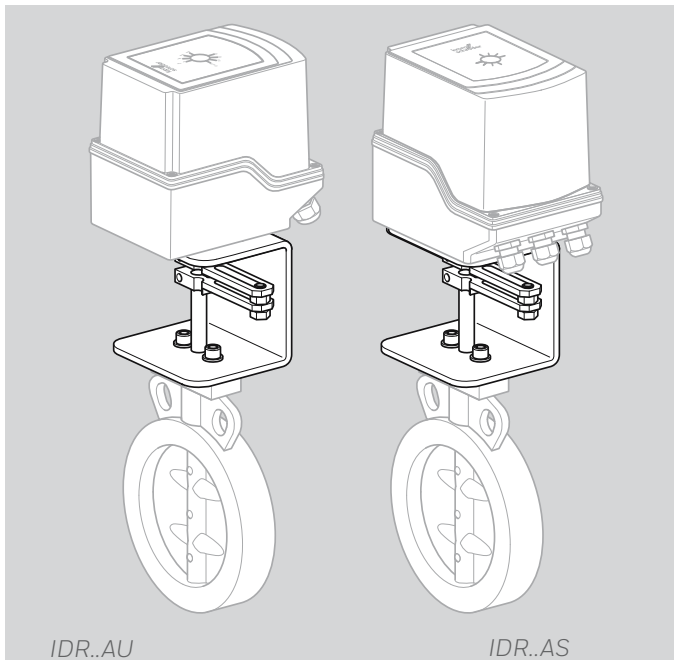

For further information on the attachment sets, see www.docuthek.com, Technical Information bulletin DKR.

Attachment with linkage

Depending on the type of butterfly valve (DKR..A = butterfly valve with stop bar, DKR..D = butterfly valve with disc clearance), the attachment set with linkage is available with or without shock suppressor. The actuator may be installed rotated by 180°.

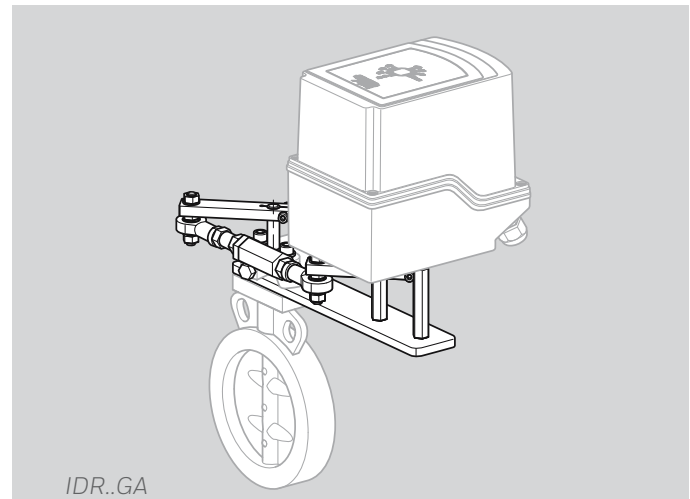

For further information on the attachment sets, see www.docuthek.com, Technical Information bulletin DKR.

8 Technical data

8.1 IC 20, IC 50

Angle of rotation: 0 – 90°, adjustable.

Holding torque = torque.

Duty cycle: 100%.

Contact rating of the cam switches:

Voltage	Min. current (resistive load)	Max. current (resistive load)
24 – 230 V, 50/60 Hz	1 mA	2 A
24 V DC	1 mA	100 mA

Line entrance for electrical connection:

3 × M20 plastic cable glands.

Screw terminals using the elevator principles for cables up to 4 mm² (single core cables) and for cables up to 2.5 mm² with wire end ferrules.

Typical designed lifetime:

Corrente di commutazione	Cicli di commutazione	
	cos φ = 1	cos φ = 0,3
1 mA	1.000.000	-
22 mA ¹⁾	-	1.000.000
100 mA	1.000.000	-
2 A	100.000	-

Three-point step signal to terminals 1 and 2:

minimum pulse duration: 100 ms,

minimum pause between 2 pulses: 100 ms.

Enclosure: IP 65, safety class: I.

Ambient temperature:

-20 to +60°C, no condensation permitted.

Storage temperature: -20 to +40°C.

8.1.1 IC 20, IC 20..E

Mains voltage:

120 V AC, -15/+10%, 50/60 Hz,

230 V AC, -15/+10%, 50/60 Hz.

Type	Running time [s/90°]		Torque [Nm]	
	50 Hz	60 Hz	50 Hz	60 Hz
IC 20-07	7.5	6.25	2.5	2
IC 20-15	15	12.5	3	3
IC 20-30	30	25	3	3
IC 20-60	60	50	3	3

IC 20

Power consumption:

4.9 VA at 50 Hz, 5.8 VA at 60 Hz.

Resistance of the feedback potentiometer: 1 kΩ, max. 1 W.

IC 20..E

Power consumption:

terminals 1, 2 and 5:

4.9 VA at 50 Hz, 5.8 VA at 60 Hz,

terminal 3:

8.4 VA at 50 Hz, 9.5 VA at 60 Hz,

in total not exceeding:

8.4 VA at 50 Hz, 9.5 VA at 60 Hz.

Technical data

Position feedback output:

4 – 20 mA, electrically isolated, max. 500 Ω load impedance.

The output is always active when supply voltage is applied to terminals 3 and 4.

Input: electrically isolated,

0 (4) – 20 mA: load impedance switchable between 50 Ω and 250 Ω ,

0 – 10 V: 100 k Ω input resistance.

8.1.2 IC 50, IC 50..E

Mains voltage:

24 V AC, -15/+10%, 50/60 Hz,

120 V AC, -15/+10%, 50/60 Hz,

230 V AC, -15/+10%, 50/60 Hz.

Type	Running time [s/90°]		Torque [Nm]
	50 Hz	60 Hz	50 Hz/60 Hz
IC 50-03	3.7	3.1	3
IC 50-07	7.5	6.25	7
IC 50-15	15	12.5	15
IC 50-30	30	25	20
IC 50-60	60	50	30

IC 50

Power consumption:

16 VA at 60 Hz, 13 VA at 50 Hz.

Resistance of the feedback potentiometer:

1 k Ω , max. 1 W, max. wiper current: 0.1 mA.

IC 50..E

Power consumption:

terminals 1, 2 and 5: 16 VA at 60 Hz, 13 VA at 50 Hz,
terminal 3: 19 VA at 60 Hz, 16 VA at 50 Hz,
in total not exceeding: 19 VA at 60 Hz, 16 VA at 50 Hz.

Feedback output:

galvanically isolated, max. 500 Ω load impedance.

The output is always active when mains voltage is applied to terminal 3.

Input: electrically isolated,

4 (0) – 20 mA: load impedance switchable between 50 Ω and 250 Ω ,

0 – 10 V: 100 k Ω input resistance.

8.2 IC 30

Angle of rotation: 0 – 90°, adjustable.

Holding torque = torque.

Mains voltage:

24 V DC, ±20%.

Line entrance for electrical connection:

3 x M16 plastic cable glands (enclosed).

Screw terminals using the elevator principles for cables

up to 2.5 mm² with wire end ferrules.

The running time changes depending on the load. It refers to the torque, see type label.

Contact rating of the cam switches:

Contact rating of the cam switches:

Voltage	Min. current (resistive load)	Max. current (resistive load)
24 – 230 V, 50/60 Hz	1 mA	2 A
24 V DC	1 mA	100 mA

Enclosure: IP 65.

Duty cycle: 100%.

Power consumption: 4 W,

when switching on: briefly 8 W.

Ambient temperature:

-15 to +60°C, no condensation permitted.

Storage temperature: -15 to +40°C.

Resistance of the feedback potentiometer:

1 kΩ, < 50 V,

recommended wiper current: 0.2 μA.

8.3 Dimensions

8.3.1 IC 20

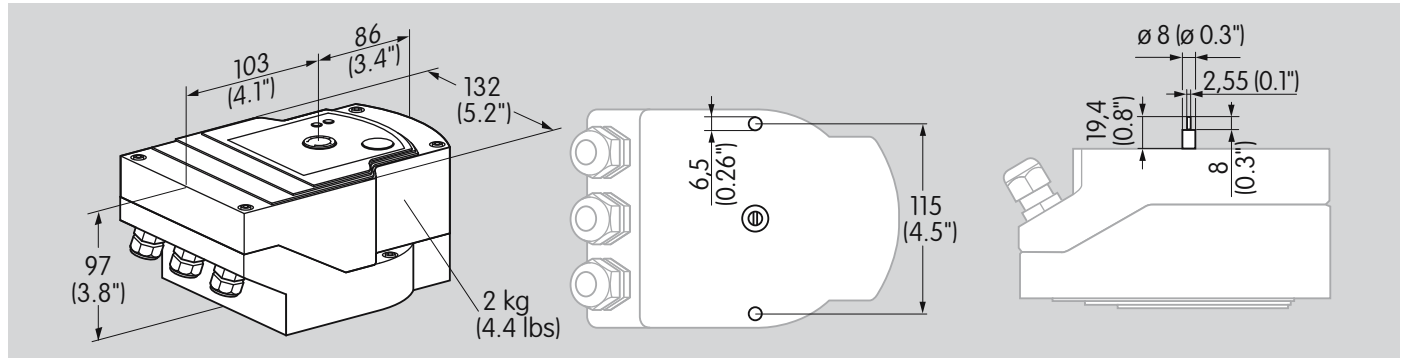

Other dimensions of IC 20 with butterfly valves BV., see www.docuthek.com, Butterfly valves BVG, BVA, BVH, Technical Information. Dimensions of IC 20 with VFC, see www.docuthek.com, Linear flow controls VFC, Technical Information.

8.3.2 IC 30

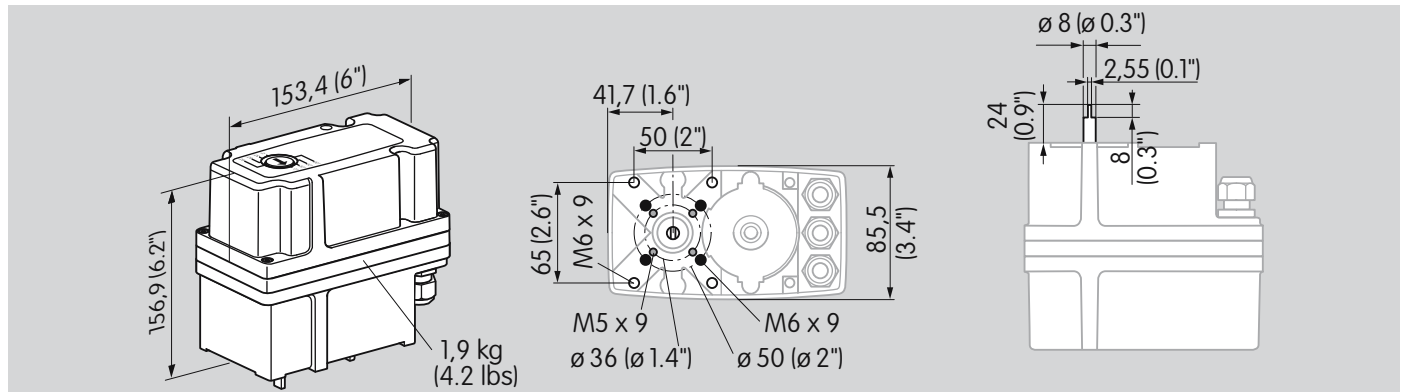

Other dimensions of IC 30 with VFC, see www.docuthek.com, Linear flow controls VFC, Technical information.

8.3.3 IC 50

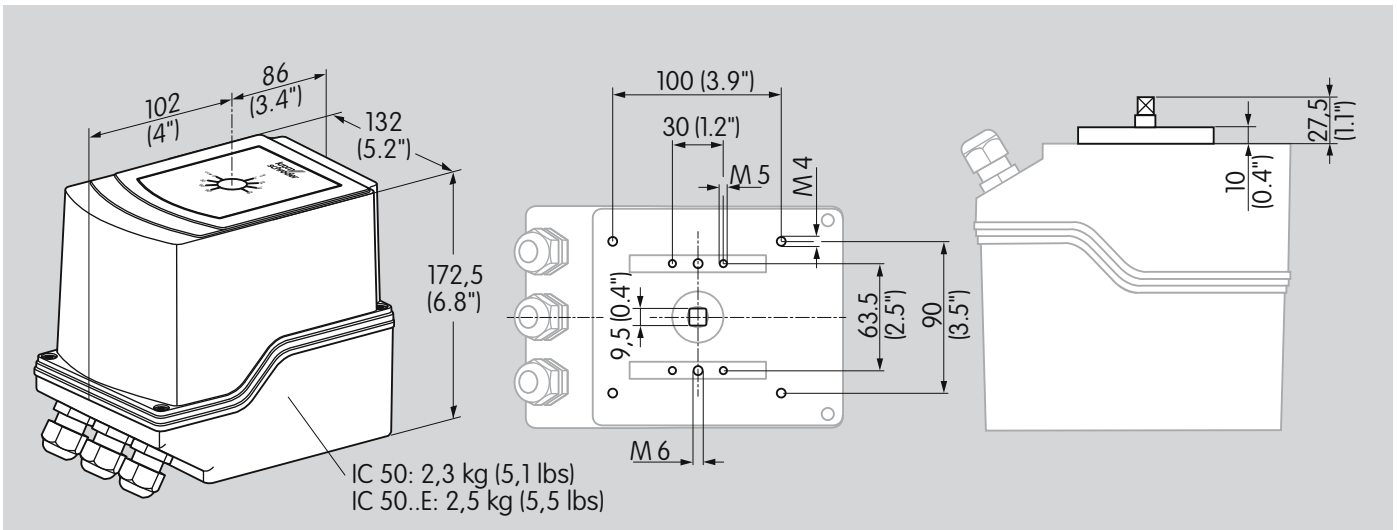

Other dimensions of IC 50 with butterfly valve DKR and various attachment sets, see www.docuthek.com, Technical information Butterfly valves DKR, IDR.

9 Converting units

See www.adlatus.org

10 Maintenance

Actuators IC suffer little wear and require little servicing.
We recommend a function check once a year.

Feedback

Finally, we are offering you the opportunity to assess this “Technical Information (TI)” and to give us your opinion, so that we can improve our documents further and suit them to your needs.

Clarity

- Found information quickly
- Searched for a long time
- Didn't find information
- What is missing?
- No answer

Comprehension

- Coherent
- Too complicated
- No answer

Scope

- Too little
- Sufficient
- Too wide
- No answer



Use

- To get to know the product
- To choose a product
- Planning
- To look for information

Navigation

- I can find my way around
- I got “lost”
- No answer

My scope of functions

- Technical department
- Sales
- No answer

Remarks

Contact

Elster GmbH
Postfach 2809 · 49018 Osnabrück
Strothweg 1 · 49504 Lotte (Büren)
Germany

Tel +49 541 1214-0
Fax +49 541 1214-370
info@kromschroeder.com
www.kromschroeder.com

The current addresses of our international agents
are available on the Internet:
www.kromschroeder.de/Weltweit.20.0.html?&L=1

We reserve the right to make technical
modifications in the interests of progress.
Copyright © 2016 Elster GmbH
All rights reserved.

